



TAKE IT PIZZEY CAFE SCREENS... MODERN, FLEXIBLE, AFFORDABLE TO THE STREET

Are you tired of chasing your cafe barriers down the street on those windy days?

Our removable rigid barriers offer a great alternative with a modern glass look.

Our acrylic and aluminium system offers quick and easy daily set-up and pack away. Posts slot into in-ground sockets for greater stability.

Ideal for cafe and restaurant alfresco dining.

Let Pizzey Streetscapes give your site the competitive edge.

Features

- Contemporary, clean and durable
- Fresh clean look
- Posts and inground sockets are made from marine grade stainless steel
- Removable panels are made from durable acrylic in anodised aluminium frames
- With our adjustable height sockets, screens always stand straight and true, even on sloping sites.
- Suits any outdoor location
- Wide range of sizes

Benefits

- Our proprietary 'O' Lid in-ground sockets have no flip-up parts to jam or break
- No need for heavy weight bags
- No more falling over or blowing away
- Low maintenance and easy to clean
- Council approved*

*most councils require special approval. Check with your local authority.



pizzey
streetscapes

Removable Screen specifications

- Rigid screen made of 6/8mm acrylic in strong clear anodised aluminium frames.
- Sockets are made from quality marine grade 316 polished stainless steel.
- Brand your screens with vinyl graphics.
- Sockets are set flush to pavement in concrete footings.
- Plan drawings can be provided for council approval.



TYPICAL PANEL CONFIGURATIONS

(CUSTOMISED PANEL SIZES CAN ALSO BE CATERED FOR)

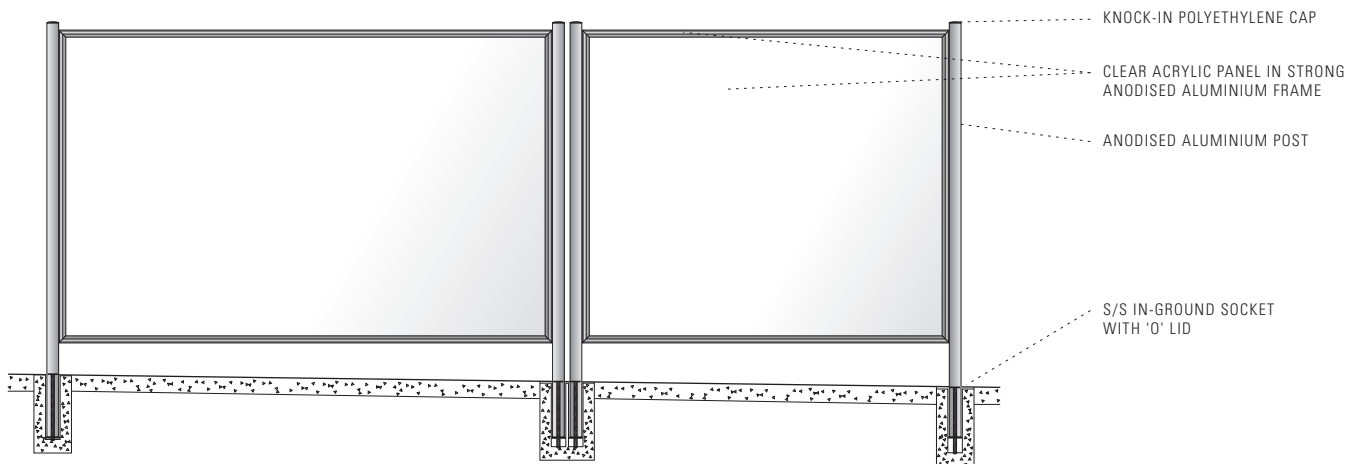

POST SOCKET PLAN

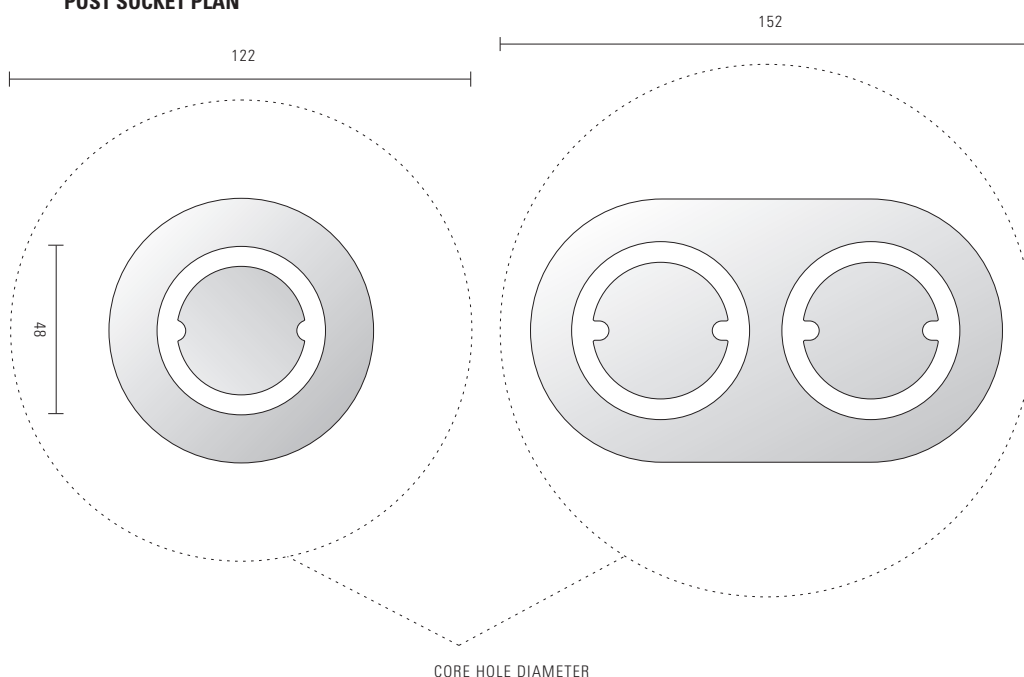

pizzey
streetscapes

For further information or a free consultation and quote please contact David Pizzey on **03 9388 1970** or visit our website at www.pizzeystreetscapes.com.au